

**Loading Machine** | Efficient materials handling in modern recycling

<b>ENGINE</b>	114 kW 153 HP
<b>WEIGHT</b>	22 - 23.5 t 48,501 - 51,808 lbs
<b>REACHES</b>	12.0 m (39.4') 11.0 m (36')



RECYCLING MACHINE  
**MHL 331**

**HANDLES ANY VOLUME**

- ▶ High-performing 114 kW Deutz turbocharged Diesel engine (TIER III/COM III/EPA III)
- ▶ Operating weight 22 - 23.5 t (48,501 - 51,808 lbs)
- ▶ Load limit control with automatic idle
- ▶ Efficient hydraulic system
- ▶ Multi functional display
- ▶ Improved lifting capacities

**HIGHLY CAPABLE**

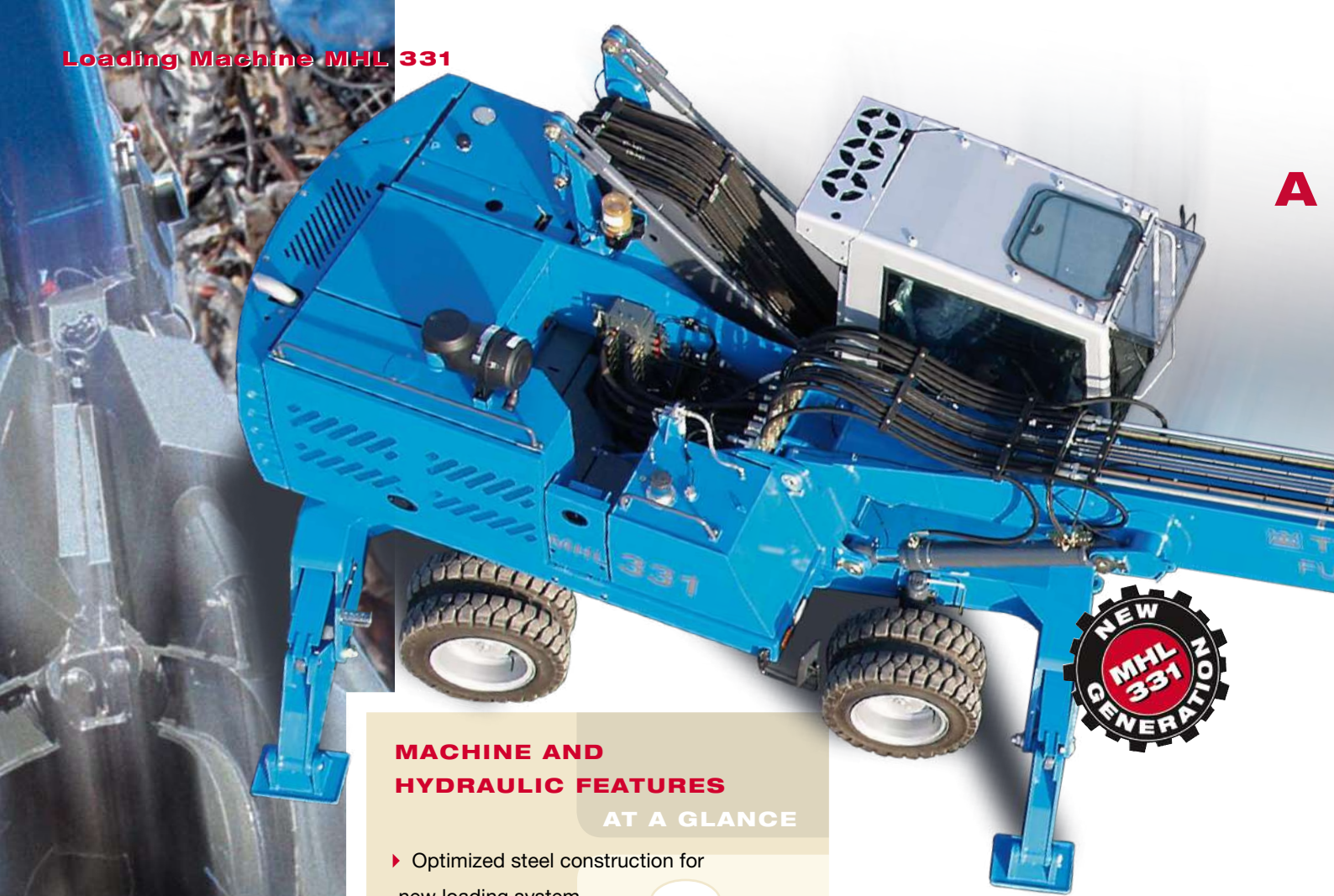

### MACHINE AND HYDRAULIC FEATURES

#### AT A GLANCE

- ▶ Optimized steel construction for new loading system
- ▶ Larger support cylinders for excellent stability
- ▶ Newly designed end-of-stroke cushioning for lift and stick cylinders provide optimum component protection
- ▶ Swing drive and gear for rapid and precise motions

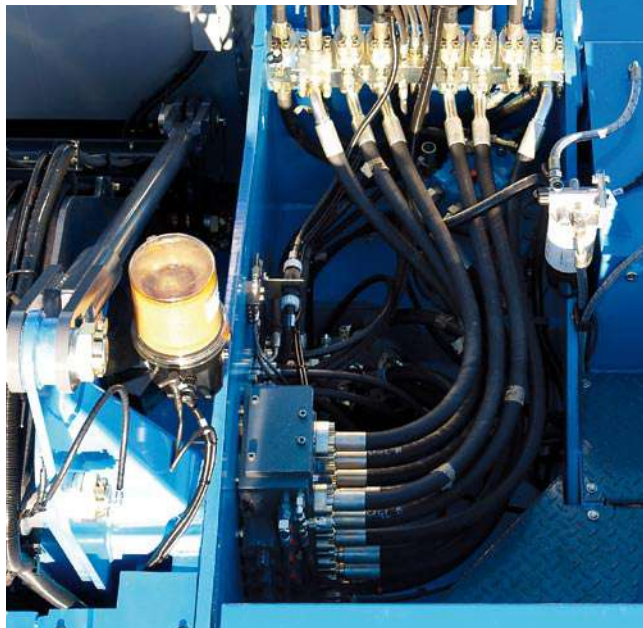

# CLEVER INVESTMENT. GET THE MOST OUT OF IT

THE MHL 331 TURBOCHARGES YOUR EFFICIENCY



## HANDLE MORE. MAKE MORE.

The MHL 331 is a top performer in the recycling business. The enormous working radius, the stress resistant design of the steel structure and the excellent maneuverability enable you to handle huge volumes and to boost your sales figures accordingly.



## TURNING PERFORMANCE

The larger swing drive combined with a newly designed gearbox allows for quick and precise turning motions. Working cycles are thus smooth and accurate, even when carrying heavy loads.



## SAFE AND SOLID

Thanks to the enlarged cylinders the distance between support points is increased, which makes for excellent stability. A new end-of-stroke cushioning has been designed to preserve the working attachments and to reduce wear and tear.



**UP W**  
**SEE EVERYTHING.**



**CAB FEATURES**  
**AT A GLANCE**



- ▶ Large panoramic windows provide a wide field of view
- ▶ Cab infinitely hydraulically height-adjustable; eye-level up to 5.20 m (17')
- ▶ Air-cushioned, back-supporting comfort seat; seat-heating and integrated air condition function optional
- ▶ All control elements within comfortable reach
- ▶ Automatically controlled air condition standard
- ▶ Optimum positioning of condenser unit optimally

**A WHOLE NEW PERSPECTIVE**

The air-conditioned cab not only offers operator comfort and ergonomic seating: Thanks to the large panoramic windows and the high position of the cab it also provides perfect situational awareness. The combination of these factors has a positive impact on operator safety and occupational health. The TEREX FUCHS cab design comprehensively supports the operator's tasks and adds to workplace comfort.



**HERE YOU BELONG!**  
**KNOW EVERYTHING. ACCOMPLISH EVERYTHING.**



**DISPLAY FEATURES**  
**AT A GLANCE**

- ▶ Large, easy-to-scan color display
- ▶ Clear symbology and text messages prevent misinterpretations
- ▶ New control electronics using CAN bus technology

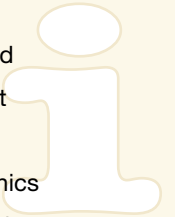

**TRUST IS GOOD.**  
**CONTROL IS BETTER YET.**

A high-resolution color display is integrated into the newly designed panel environment. Important operating data are presented precisely and clearly. Thus, information on operating conditions is available at a single glance. And, by the way, the display is just one of the many elements of the newly designed CAN bus control electronic system, a system that simplifies retrofitting further options later on.

# RAW MATERIALS - TOO

THE TEREX FUCHS RECYCLING PRINCIPLE: MORE INTELLIGENT. MORE

## HIGH PERFORMANCE AT LOW COST

Powerful, quiet and fuel efficient – these are the distinguishing characteristics of the Deutz Diesel engine. At 114 kW (153 HP) and a maximum torque of 680 Nm there is always sufficient power at your disposal, even in demanding situations. Pre-programmed efficiency! The EMR 3 control substantially reduces noise emission as compared to conventional engine control systems. Of course, the engine is fully compliant with emission standards Tier III (COM III / EPA III).

## KEEP COOL

The separate cooling system maintains ideal temperatures at every point of the machine, thus reducing wear to a minimum. The hydrostatically driven oil cooling fan with thermostatic speed control and the water-intercooler that is connected by a viscous-coupling achieve excellent cooling performance while operating silently. This enables operations in ambient temperatures up to 50°C.



## ENGINE FEATURES

### AT A GLANCE

- ▶ High performance at low fuel consumption
- ▶ EMR 3 engine control for low noise emission
- ▶ Reduced exhaust emission for operation in halls

Illustration similar

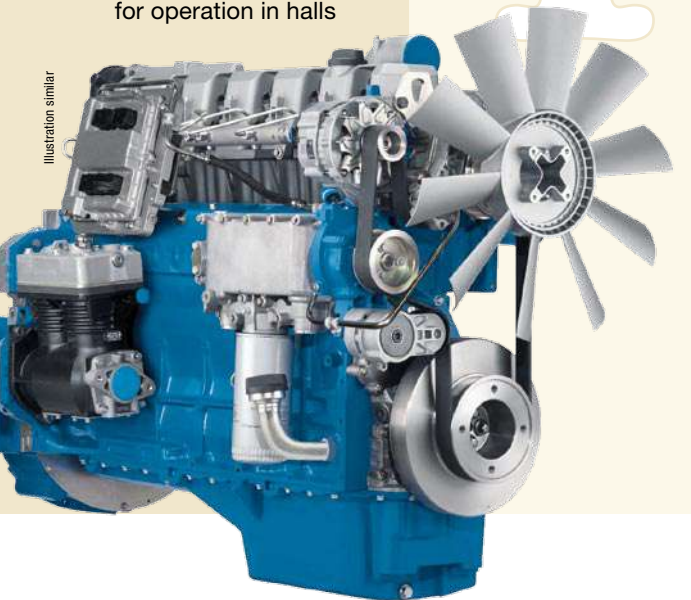

**VALUABLE TO WASTE**  
**E COMFORTABLE. MORE EFFICIENTLY**



**COOLING SYSTEM FEATURES AT A GLANCE**

- ▶ Excellent cooling performance and low noise emission
- ▶ Optimized arrangement of radiator and oil cooler
  - ▶ Enlarged, easy to clean oil cooler
  - ▶ Dirt resistant water intercooler
- ▶ Air conditioning compressor directly attached to the engine

**SERVICING IS NO SWEAT**

Component parts all defy dirt. The easily accessible maintenance platform substantially facilitates servicing; components are located within easy view and reach. Platform access is via side-mounted maintenance access steps. Intercooler and oil-cooler are within easy reach.



**Loading Machine MHL 331**





# **NEW PERFORMANCE HORIZONS**

**MOBILE LOADING MACHINES FOR MATERIAL HANDLING AND SORTING APPLICATIONS**



# WORKING DIAGRAM

MHL 331 (SERIES D) REACH 12.0 m (39.4')

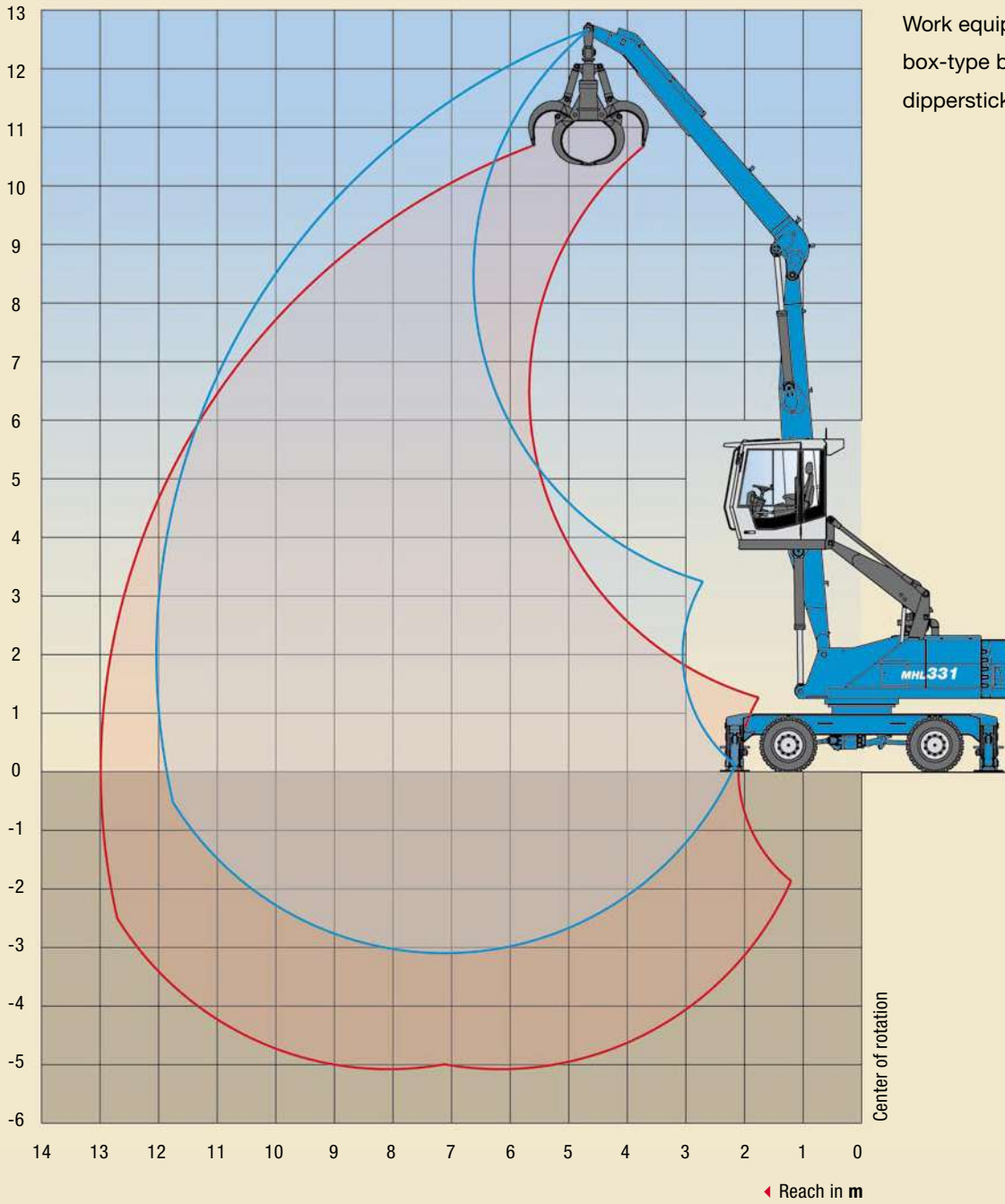

# LIFTING CAPACITY

**MHL 331 (SERIES D) REACH 12.0 m (39.4')**

HEIGHT m	UNDERCARRIAGE STABILIZERS	REACHES m					
		4.5	6	7.5	9	10.5	12
10.5	non supported			(3.7)			
	4-pt. supported			4.3* (4.3*)			
9	non supported			(3.8)	(2.8)		
	4-pt. supported			5.1* (5.1*)	4.0* (4.0*)		
7.5	non supported			(3.8)	(2.8)	(2.1)	
	4-pt. supported			5.1* (5.1*)	4.3 (4.8*)	3.1* (3.1*)	
6	non supported			(3.7)	(2.7)	(2.1)	
	4-pt. supported			5.3* (5.3*)	4.3 (4.9*)	3.3 (4.1)	
4.5	non supported		(5.1)	(3.6)	(2.6)	(2.0)	
	4-pt. supported		6.6* (6.6*)	5.6 (5.8*)	4.2 (5.2*)	3.3 (4.0)	
3	non supported	(7.3)	(4.7)	(3.4)	(2.5)	(2.0)	(1.5)
	4-pt. supported	10.0* (10.0*)	7.6* (7.6*)	5.4 (6.3*)	4.1 (5.0)	3.2 (4.0)	2.6 (3.1*)
1.5	non supported	(6.5)	(4.3)	(3.1)	(2.4)	(1.9)	(1.5)
	4-pt. supported	11.5* (12.1*)	7.2 (8.7*)	5.2 (6.5)	3.9 (4.9)	3.1 (3.9)	2.6 (3.1*)
0	non supported	(6.1)	(4.1)	(3.0)	(2.3)	(1.9)	
	4-pt. supported	9.2* (9.2*)	6.9 (8.8)	5.0 (6.3)	3.8 (4.8)	3.1 (3.8)	
-1.5	non supported	(5.8)	(3.9)	(2.9)	(2.2)	(1.8)	
	4-pt. supported	7.4* (7.4*)	6.7 (8.6)	4.9 (6.1)	3.8 (4.7)	3.0 (3.8)	
-3	non supported			(2.8)			
	4-pt. supported			4.8 (6.1)			

Capacity values are stated in metric tons (t) or lbs. The pump pressure is 360 bar (5220 psi). The values, in accordance with ISO 10567, amount to 75 % of the static tipping load or 87 % of the hydraulic lifting force (marked \*). They apply to slewing operations through 360° on a firm and level surface. Values in brackets apply to the longitudinal direction of the undercarriage. "Non-supported" values only apply when the load is hoisted above the front or rear axle. The weight of the attached hoisting equipment (grab, magnet, load hook) must be deducted from the capacity values. If the TEREX FUCHS quick-change system is mounted on the boom, capacity is reduced by 300 kg (661 lbs). In accordance with EC guidelines, hose-rupture safety valves on the lift cylinders and an overload warning device are required for crane operations.

## RECOMMENDED ATTACHMENTS

Loading system 12.0 m (39.4')

<b>LIFT HOOKS</b>	10 t
<b>TEREX FUCHS CACTUS GRABS</b>	0.4 m <sup>3</sup> (open or half-closed shells)
<b>GRAB FOR LIGHTWEIGHT MATERIALS</b>	0.6 m <sup>3</sup>
<b>TEREX FUCHS MAGNET PLATE MP 1150</b>	dia. = 1150 mm with magnet system 11 kW

# WORKING DIAGRAM

MHL 331 (SERIES D) REACH 11.0 m (36')

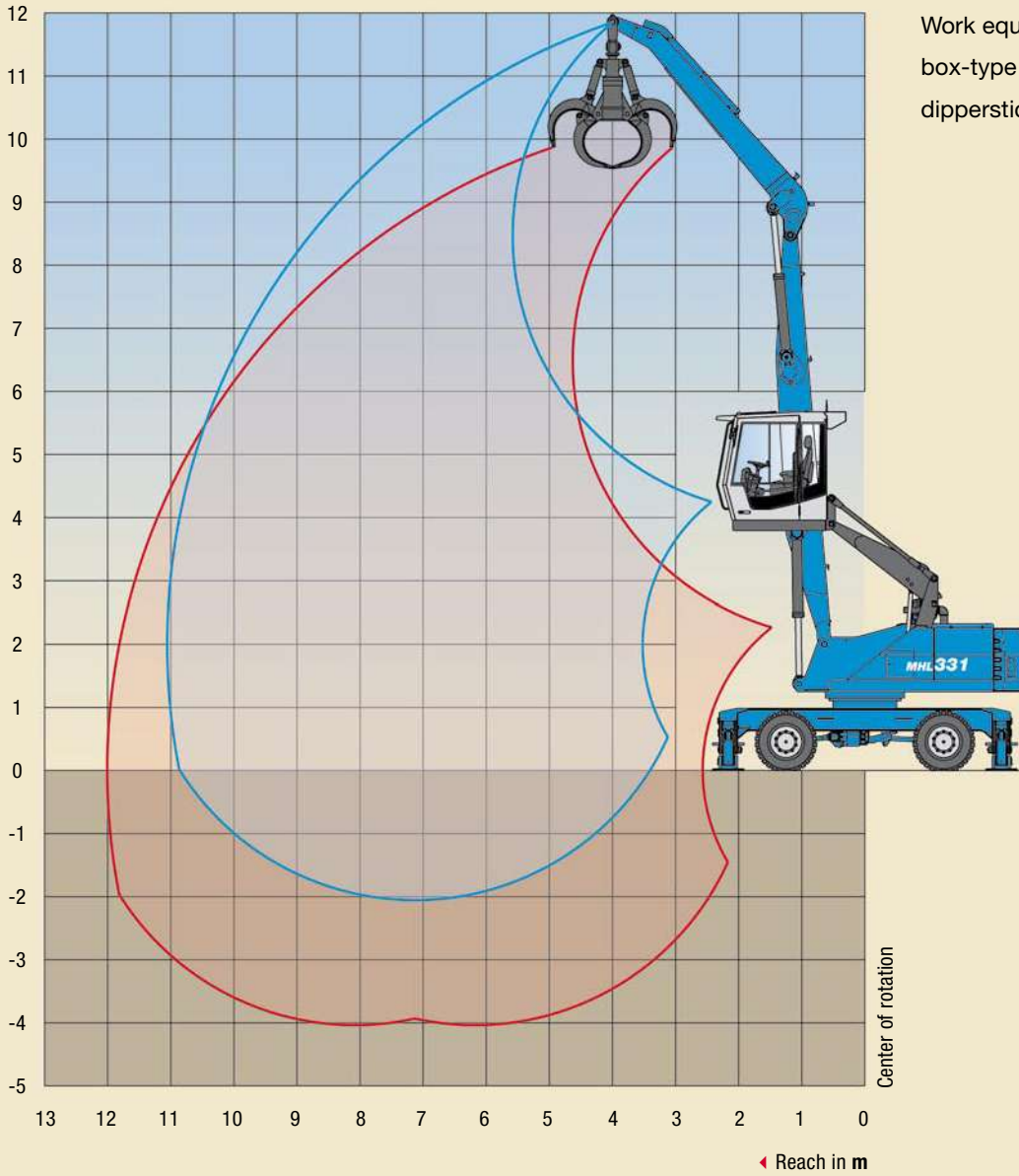

Work equipment:  
box-type boom 6.5 m (21.3'),  
dipperstick 4.4 m (14.4')

# LIFTING CAPACITY

## MHL 331 (SERIES D) REACH 11.0 m (36')

HEIGHT m	UNDERCARRIAGE STABILIZERS	REACHES m				
		4.5	6	7.5	9	10.5
10.5	non supported		(5.2)			
	4-pt. supported		5.6* (5.6*)			
9	non supported		(5.3)	(3.6)		
	4-pt. supported		6.3* (6.3*)	5.6* (5.6*)		
7.5	non supported		(5.2)	(3.7)	(2.7)	
	4-pt. supported		6.4* (6.4*)	5.7 (5.8*)	4.2 (4.9*)	
6	non supported		(5.1)	(3.6)	(2.6)	
	4-pt. supported		6.8* (6.8*)	5.6 (6.0*)	4.2 (5.2)	
4.5	non supported	(7.5)	(4.8)	(3.4)	(2.6)	(2.0)
	4-pt. supported	(9.6* (9.6*))	7.6* (7.6*)	5.5 (6.4*)	4.1 (5.1)	3.2 (4.0)
3	non supported	(6.8)	(4.5)	(3.3)	(2.5)	(2.0)
	4-pt. supported	11.6* (11.6*)	7.4 (8.5*)	5.3 (6.6)	4.0 (5.0)	3.2 (3.9)
1.5	non supported	(6.2)	(4.2)	(3.1)	(2.4)	(1.9)
	4-pt. supported	10.1* (10.1*)	7.1 (9.0)	5.1 (6.4)	3.9 (4.9)	3.1 (3.9)
0	non supported	(5.9)	(4.0)	(3.0)	(2.3)	(1.9)
	4-pt. supported	7.0* (7.0*)	6.8 (8.8)	5.0 (6.2)	3.8 (4.8)	3.1 (3.9)
-1.5	non supported		(3.9)	(2.9)	(2.3)	
	4-pt. supported		6.8 (8.7)	4.9 (6.2)	3.8 (4.7)	

Capacity values are stated in metric tons (t) or lbs. The pump pressure is 360 bar (5220 psi). The values, in accordance with ISO 10567, amount to 75 % of the static tipping load or 87 % of the hydraulic lifting force (marked \*). They apply to slewing operations through 360° on a firm and level surface. Values in brackets apply to the longitudinal direction of the undercarriage. "Non-supported" values only apply when the load is hoisted above the front or rear axle. The weight of the attached hoisting equipment (grab, magnet, load hook) must be deducted from the capacity values. If the TEREX FUCHS quick-change system is mounted on the boom, capacity is reduced by 300 kg (661 lbs). In accordance with EC guidelines, hose-rupture safety valves on the lift cylinders and an overload warning device are required for crane operations.

### RECOMMENDED ATTACHMENTS

Loading system 11.0 m (36')

<b>LIFT HOOKS</b>	10 t
<b>TEREX FUCHS CACTUS GRABS</b>	0.4 m <sup>3</sup> (open or half-closed shells)
<b>TEREX FUCHS CACTUS GRABS</b>	0.6 m <sup>3</sup> (open or half-closed shells)
<b>GRAB FOR LIGHTWEIGHT MATERIALS</b>	0.8 m <sup>3</sup>
<b>TEREX FUCHS MAGNET PLATE MP 1150</b>	dia. = 1150 mm with magnet system 11 kW
<b>TEREX FUCHS MAGNET PLATE MP 1250</b>	dia. = 1250 mm with magnet system 13 kW

# TECHNICAL DATA

## MHL 331 (SERIES D)

### OPERATING WEIGHT

22 t - 23.5 t (48,501 lbs - 51,808 lbs)

### DIESEL ENGINE

<b>MANUFACTURER AND MODEL</b>	Deutz TCD 2012 L06 2V
<b>DESIGN</b>	6 Cylinder Inline
<b>ENGINE CONTROL</b>	EMR III
<b>TYPE</b>	4-stroke diesel engine, direct common-rail fuel-injection, turbocharger with intercooling
<b>ENGINE OUTPUT</b>	114 kW (153 HP)
<b>NOMINAL SPEED</b>	2000 min <sup>-1</sup>
<b>DISPLACEMENT</b>	6.0 l (1.6 US GAL)
<b>COOLING SYSTEM</b>	Liquid intercooling with temperature controlled fan speed
<b>EMISSION STANDARDS</b>	COM III and EPA Tier III
<b>AIR FILTER DESIGN</b>	Two-stage filter with safety valve
<b>FUEL CAPACITY (USABLE)</b>	300 l (79.25 US GAL)

### ELECTRICAL SYSTEM

<b>OPERATING VOLTAGE</b>	24 V
<b>BATTERIES</b>	2 x 12 V / 100 Ah / 760 A (nach EN)
<b>LIGHTING SET</b>	1 dipper-stick-mounted floodlight, 1 headlight mounted to upper carriage, 1 floodlight attached to cabin floor, rear side-marker and turn signal lamps
<b>OPTION</b>	Magnet plate 11 kW or 13 kW

### TRAVEL DRIVE

	Hydrostatic drive through infinitely variable axial piston motor and directly mounted; travel brake valves, two-speed power shift gear, 4-wheel drive
<b>TRAVEL SPEED 1ST GEAR</b>	max 5 km/h (3.1 mph)
<b>TRAVEL SPEED 2ND GEAR</b>	max 20 km/h (12.4 mph)
<b>GRADEABILITY</b>	max 50%
<b>TURNING RADIUS</b>	7.0 m (22.9')

### SWING SYSTEM

<b>RING GEAR</b>	Internally toothed ball ring gear (double row)
<b>DRIVE</b>	Two-stage planetary gear with integrated multi-disc brake
<b>UPPER CARRIAGE SWING SPEED</b>	Infinitely variable from 0 - 8 min <sup>-1</sup>
<b>PIVOT BRAKE</b>	Electrically operated

### UNDERCARRIAGE

<b>FRONT AXLE</b>	Planetary drive axle with integrated drum brake, rigidly mounted max steering angle: 28°
<b>REAR AXLE</b>	Oscillating planetary drive rear axle with integrated drum brake and selectable oscillating axle lock
<b>TIRES</b>	Solid rubber, elastic tires 8-fold 9.00 - 20
<b>STABILIZERS</b>	4-point-stabilizers



### BRAKE SYSTEM

<b>SERVICE BRAKE</b>	Hydraulically operated single circuit brake system acting on all four wheel pairs
<b>PARKING BRAKE</b>	Electrically operated disc brake at transmission, acting on both front and rear axle

### HYDRAULIC SYSTEM

	REXROTH mobile hydraulic system with load limit control, automatic idle and fuel conserving power demand control. Separate oil cooler, temperature controlled fan speed Hydraulic fluid filter: integrated in the oil tank; maintenance interval: 3.000 operating hrs. Central lubrication system
<b>MAX PUMP CAPACITY</b>	380 l/min
<b>MAX OPERATING PRESSURE</b>	320 / 360 bar (4641 / 5221 psi)
<b>HYDRAULIC OIL TANK</b>	340 l (90 US GAL)

### OPERATOR CAB

	Elastically supported, infinitely variable hydraulically height-adjustable with max. eye level of 5.2 m / 17'06". Sound-deadened, heat-insulated panoramic windows for optimum all-around view, windshield with pull-down sunblind that slides under cab roof, sliding window in cab door, steering column height and tilt adjustable
<b>HEATING</b>	Infinitely variable hot water heating with 3-speed fan, 4 adjustable defroster nozzles
<b>OPERATOR'S SEAT</b>	Air-cushioned comfort-seat with integrated headrest, safety belt and lumbar support, seat heating with integrated a/c function optional. Seat position, seat inclination and seat cushion multi-adjustable in line with position of armrests and pilot control units, allowing fatigue-free operation
<b>MONITORING</b>	Ergonomic instrument layout, glare-free. Function monitoring; automatic warning and storage of deviating operating conditions, e.g. filter pressure w. warning indicator and shutdown of pilot controls, warning indicator resp. shutdown of pilot controls when exceeding hydraulic oil temperature limits
<b>AIR CONDITION</b>	Automatic air condition

### SAFETY INSTALLATIONS

For crane operations in accordance with EN 474-5

### OFFICIAL HOMOLOGATION

Certification according to CE-regulations





# EQUIPMENT

## MHL 331 (SERIES D)

ENGINE	SERIES	OPTION
Turbocharger	●	
Intercooling	●	
Direct electronic fuel injection/common Rail	●	
Automatic idle	●	
Engine pre-heating		●
Interface for engine diagnosis	●	
Fan drive temperature controlled	●	

UNDERCARRIAGE	SERIES	OPTION
2-speed power-shift transmission	●	
4-point-stabilizers	●	
4-point stabilizers individually controllable		●
Stabilizer (outrigger) cylinders with integrated two-way check valves	●	
All-wheel drive	●	
Piston rod protection on stabilizer cylinder	●	
Stabilizer (outrigger) plate 500 x 350	●	
Rear axle oscillating lock	●	
Special paint		●
Drum brakes	●	
Tool box	●	

UPPER CARRIAGE	SERIES	OPTION
Electrical refueling pump		●
Lighting protection		●
Maintenance hood, actuated by gas spring, w. mechanical locking device	●	
Lockable cleaning access openings on radiator	●	
Separate radiator system for ambient temperatures up to 50°C	●	
Separate oil cooler w. temperature controlled fan drive	●	
Back-up alarm		●
Special paint		●
Quick-drain valve on fuel tank (delivered in tool box)	●	
Quick-drain valve on hydraulic oil tank	●	
Quick-drain valve on radiator	●	
Quick-drain valve on engine-oil pan	●	
Reversible fan for radiator and hydraulic oil cooler		●

CAB	SERIES	OPTION
Lift-up skylight in cabin roof	●	
Air cushioned operator's seat with headrest, safety belt and lumbar-support	●	
FOPS-protective grating		●
Front/roof protective grating		●
Hinged front windshield	●	
Front-windows break-resistant (LEXAN)		●
Bulletproof glass, front and top		●
Cab system, height adjustable	●	
Air condition	●	
Steering column, height and tilt adjustable	●	
Multi functional display	●	
Fire extinguisher, dry powder		●
Preparation for radio		●
Cassette radio		●
Radio and CD Player		●
Rotating beacon		●
Sliding window in cab door	●	
Safety glass	●	
Seat heating with integrated a/c function		●
Engine independent heating		●
Windscreen washer system	●	

EQUIPMENT	SERIES	OPTION
Working floodlights on cab floor	●	
Working floodlights on upper carriage	●	
Floodlight, dipperstick mounted	●	
Hydraulic oil preheating		●
Close proximity range limiter for dipperstick	●	
Coolant and hydraulic oil level monitoring system	●	
Break protection for lift cylinder		●
Pipe break protection for stick cylinder		●
Dipperstick shock protection	●	
Lubrication of grab suspension by central lubrication system	●	
Overload warning installation		●
Overload shutdown		●
XENON-floodlight on dipperstick		●
XENON-floodlight on upper carriage		●
XENON-floodlight on cab roof		●
Quick-connect coupling on dipperstick	●	

**DIMENSIONS**

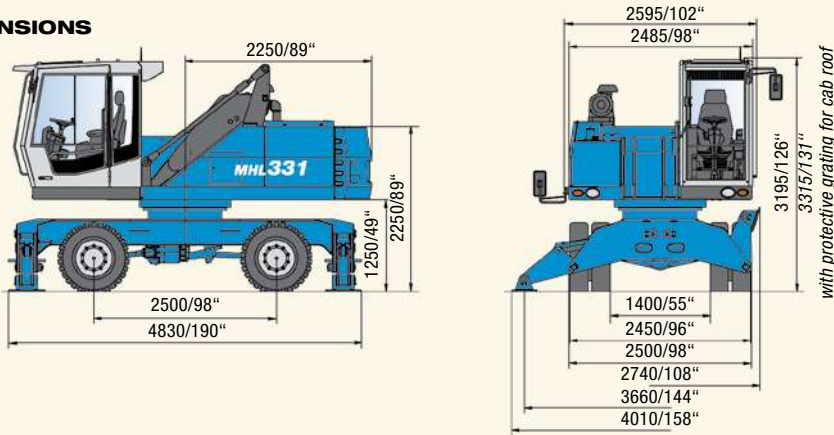

**TRANSPORT DIMENSIONS**

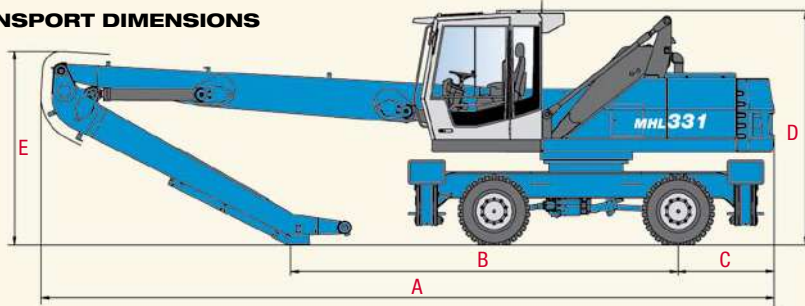

DIMENSIONS	REACH 12.0 m (39.4')	REACH 11.0 m (36')
A	9,900 mm (390")	9,950 mm (392")
B	4,280 mm (169")	5,250 mm (207")
C	1,300 mm (51")	1,300 mm (51")
D	3,195 mm (126") / *3,315 mm (*131")	3,195 mm (126") / *3,315 mm (*131")
E	3,100 mm (122")	2,650 mm (104")

\*with protective grating for cab roof

**DISTRIBUTOR**